

UNION

MODEL CODE : KUS

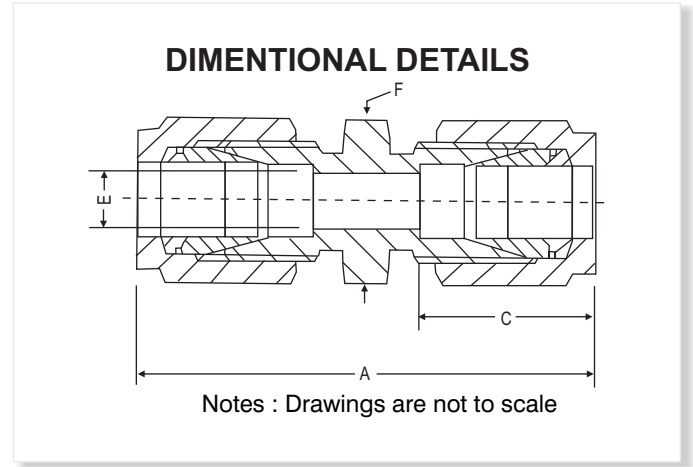

HOW TO ORDER

Dimension, in.

Tube OD	Part Number	A	C	E	F
1/8	KS2US2	1.40	0.50	0.09	7/16
1/4	KS4US4	1.61	0.60	0.19	1/2
5/16	KS5US5	1.69	0.64	0.25	9/16
3/8	KS6US6	1.77	0.66	0.28	5/8
1/2	KS8US8	2.02	0.90	0.41	13/16
5/8	KS10US10	2.05	0.96	0.50	15/16
3/4	KS12US12	2.11	0.96	0.62	1 1/16
7/8	KS14US14	2.17	1.02	0.72	1 3/16
1	KS16US16	2.55	1.23	0.88	1 3/8

Dimension, mm.

Tube OD	Part Number	A	C	E	F
6	KSUSM6	41.0	15.3	4.8	12.7
8	KSUSM8	43.2	16.2	6.4	14.0
10	KSUSM10	46.2	17.2	7.9	15.8
12	KSUSM12	51.2	22.8	9.5	22.0
16	KSUSM16	52.0	24.4	12.7	24.0
18	KSUSM18	53.5	24.4	15.1	27.0
20	KSUSM20	55.0	26.0	15.9	30.0
25	KSUSM25	65.0	31.3	21.8	35.0

Flow Serve

Dimensions and specifications shown are approximate, may vary from time to time.

Note : A and C dimensions are typical finger-tight

Compression tube fittings are ordered by part numbers as listed in this catalogue and other sizes will be available on request.

FOR OTHER OPTIONAL ITEMS, PLEASE CONTACT FACTORY FOR DELIVERY AND MINIMUM QUANTITY OF ORDER.

Note : Specifications and dimensions given in this product catalogue represents the state of engineering at the time of printing.

Modifications may take place and materials specified may be replaced by others without prior notice.